



MANUAL DE INSTALACIÓN

Sistema de Enganche Reforzado ST5 SE095

Mercedes Benz Sprinter
515 Minibus 19 + 1 2013 +
416 MOD. 2021 + (No incluye acople)

1 CONTENIDO

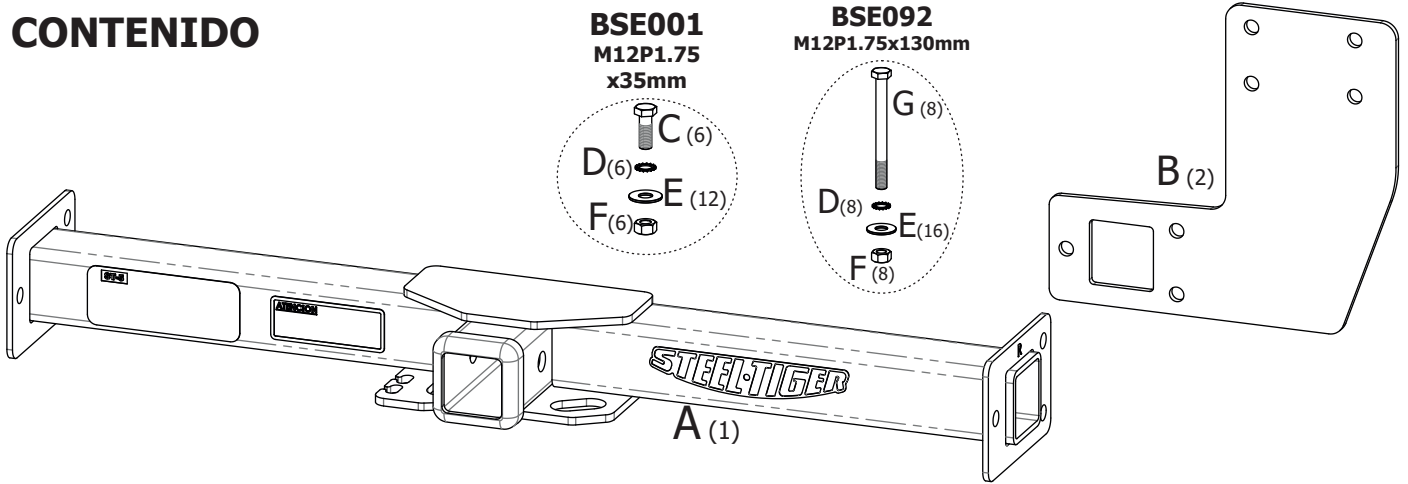

2 HERRAMIENTAS NECESARIAS

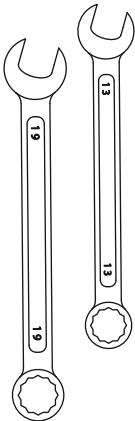

3 COLOCACIÓN DE PIEZAS "B"

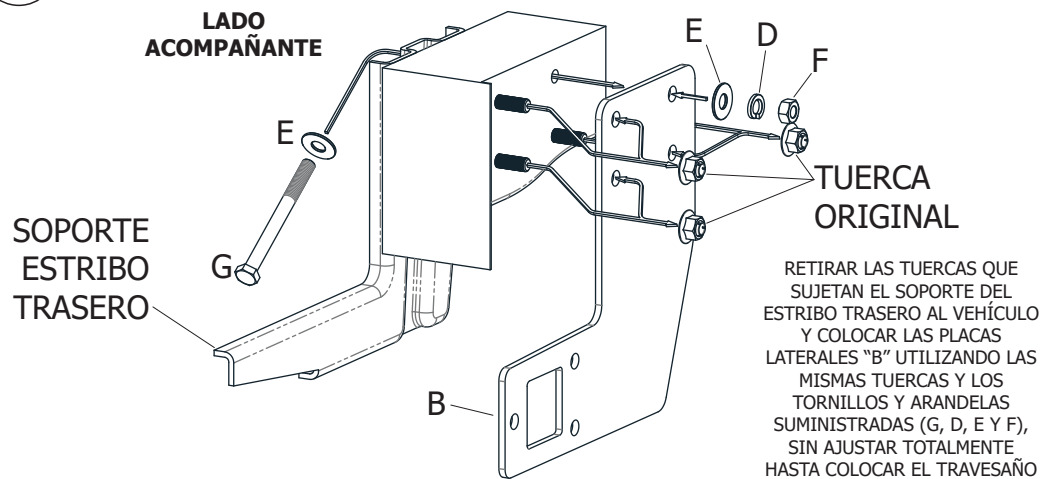

3 COLOCACIÓN DE PIEZA "A"

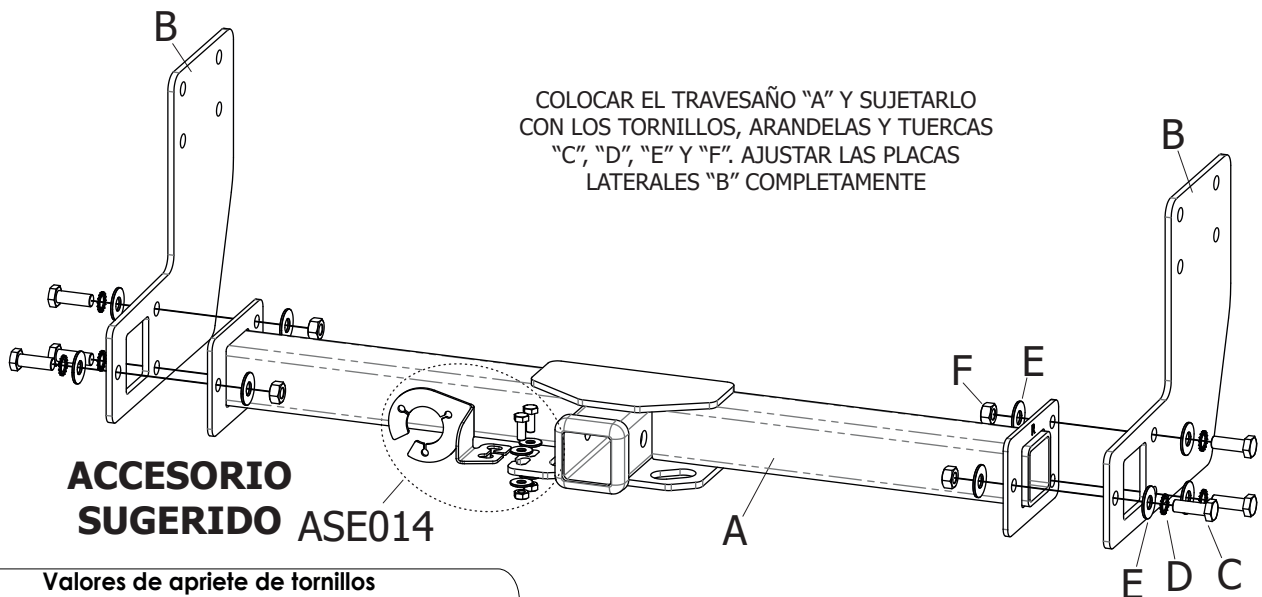

Valores de apriete de tornillos

Unidades	M4	M6	M8	M10	M12	M14
Kg.m	0,3	1	2,5	5,1	8,7	14
Coeficiente de fricción: $\mu=0,14$						